

FIL ROUGE  
5<sup>Th</sup> ELEMENT OXI UP  
SCHERMI CONTENITORI  
UNIVERSALI PIEGO  
CHIUDO SEGUO JERA  
ENOSI E.O.S. IULIO  
ELITE DELTA I-MEET  
PAUSA CONVIVIO  
FUNGO SEGNO ICARO  
NICE POINT

LAS®

reception



**Una collezione reception che si caratterizza per:**

**01/** Elevata componibilità. **02/** Frontali a fasce. **03/** Mensole in legno e vetro. **04/** Fasce superiori in vetro o in policarbonato con led. **05/** Elementi storage di supporto. **06/** Moduli conversazione ad altezza 73,6 cm. **07/** Canali porta cavi e kit di elettrificazione. **08/** Led opzionale per retroilluminazione dei pannelli. **09/** 4 finiture di legni e 2 tinte unite. **10/** 3 finiture di vetri.

**A collection of reception counters characterised by:**

**01/** High modularity. **02/** Front horizontal panels. **03/** Wood and glass shelves. **04/** Upper glass or polycarbonate panels with LEDs. **05/** Supporting storage units. **06/** Speak-through central modules, height 73.6 cm. **07/** Cable and wiring channels and fittings. **08/** Optional LEDs for panels back-lighting. **09/** 4 wood finishes, 2 plain colours. **10/** 3 glass finishes.

**Une collection de banques d'accueil caractérisée par :**

**01/** Haute modularité. **02/** Panneaux frontaux à bandes. **03/** Étagères en bois et verre. **04/** Bandes supérieures en verre ou en polycarbonate avec LED. **05/** Éléments de rangement de support. **06/** Module conversation à hauteur 73,6 cm. **07/** Canaux passe-câbles et kit électricité. **08/** LED en option pour rétro-éclairage des panneaux. **09/** 4 finitions en bois et 2 couleurs pleins. **10/** 3 finitions en verre.









cod. 12

→ Modulo frontale a fasce orizzontali e mensola in legno.  
 Front module with horizontal bands and wooden shelf.  
 Module frontal à bandes horizontales et étagère en bois.



↑ Contenitori Storage a cassetto estraibile per l'intensa operatività.  
 Storage containers with removable drawer for high-pace activity.  
 Rangements Storage à tiroir extractible pour une activité dynamique.

**Nice è una collezione reception ben strutturata e ricca di componenti ed accessori che consente di progettare composizioni di grande complessità e di forte impatto scenico.**

Nice is a well structure reception system enriched by many components and accessories that can be combined to design compositions of great complexity and strong visual impact.

Nice est une collection de comptoirs d'accueil bien structurée et riche en composants et accessoires qui permettent de concevoir compositions d'une grande complexité à fort impact visuel.





cod. 67

**L'articolazione delle altezze definisce le differenti funzioni della reception: operatività, ricevimento in piedi, conversazione o accoglienza di ospiti diversamente abili. Nice soddisfa ogni esigenza senza mai perdere la sua eleganza.**

Different heights to define the various functions of the reception counter: operation, standing reception, conversation or welcoming of guests with disabilities. Nice meets all needs without ever losing its elegance.

L'articulation des hauteurs trace les différentes fonctions de l'accueil : opérations, accueil debout, conversation ou accueil de personnes en situation de handicap. Nice satisfait toutes les exigences tout en gardant son élégance sans jamais la perdre.



←  
Mensola in vetro e fianco di finitura con profilo in alluminio.  
Glass shelf and finishing side panel with aluminium profile.  
Étagère en verre et côté de finition avec profil en aluminium.







**La composizione lineare con mensola in vetro, posta a parete o a centro stanza, si impone per le linee decise e per l'abbinamento di materiali e finiture diverse. Il punto informativo o di accoglienza diventano espressione di qualità e stile di colui che riceve.**

The linear composition with glass shelf, against the wall or at the centre of the room, stands out for its clear lines and for the combination of different materials and finishes. The info-point or reception counter becomes an expression of the quality and style of the host.

Cette composition linéaire avec étagère en verre, contre la paroi ou au centre de la pièce, est caractérisée par des lignes fortes et par la combinaison de différents matériaux et finitions. Le point d'information ou d'accueil devient expression de qualité et style de ceux qui accueillent le visiteur.



cod.CR 01

cod.CP 01



cod.30



→ Fianco terminale con profilo in alluminio cromo satinato.  
End side panel edged with satin chrome-finished aluminium profile.  
Côté terminal avec bord profilé en aluminium chromé satiné.









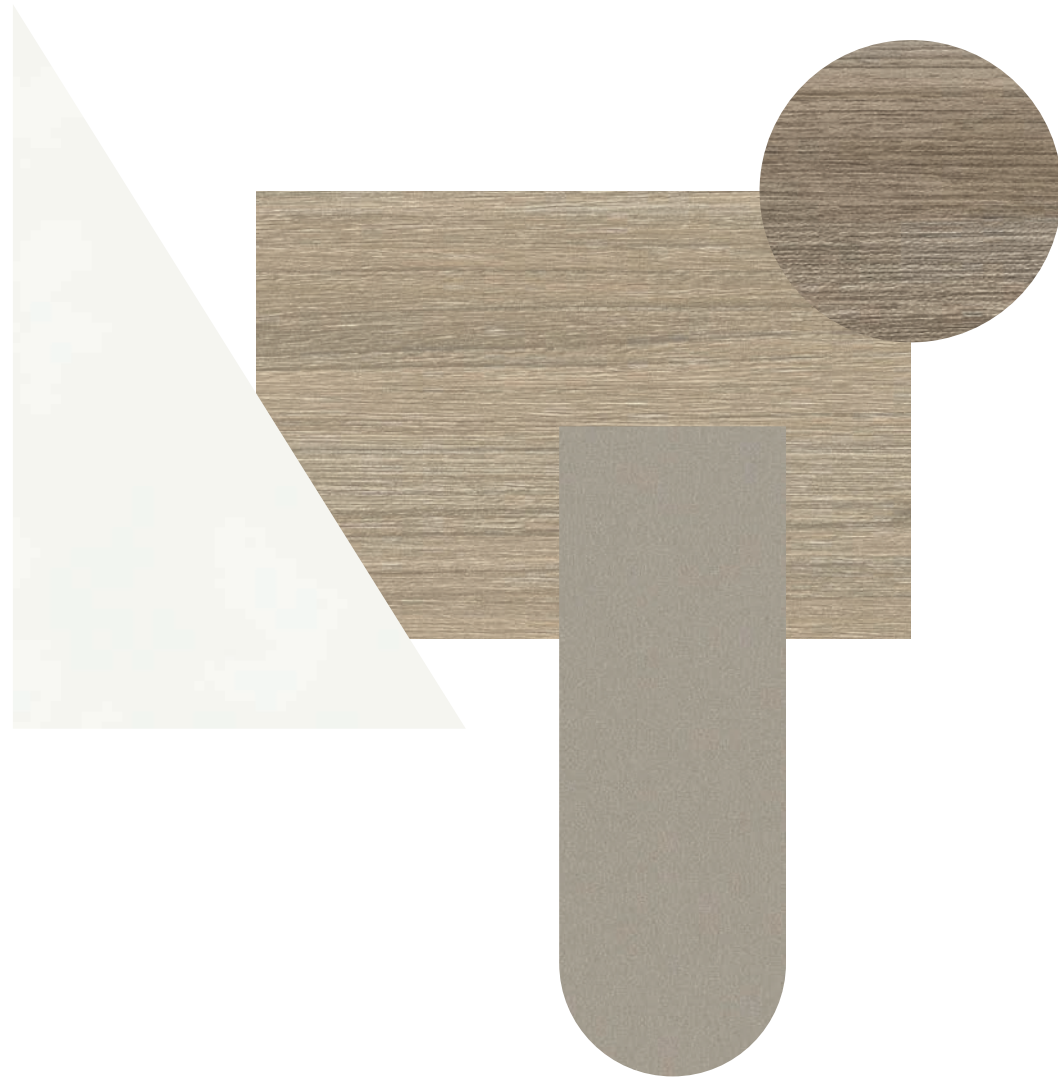

**Moduli**  
Modules | Modules

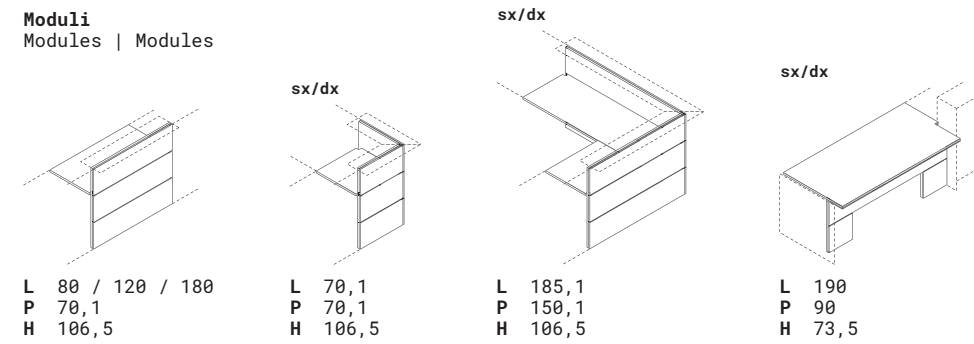

L 80 / 120 / 180  
P 70,1  
H 106,5

sx/dx  
L 70,1  
P 70,1  
H 106,5

sx/dx  
L 185,1  
P 150,1  
H 106,5

sx/dx  
L 190  
P 90  
H 73,5

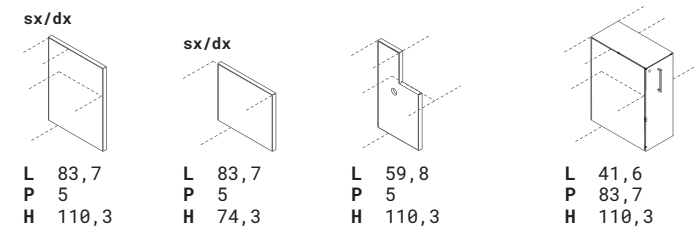

sx/dx  
L 83,7  
P 5  
H 110,3

sx/dx  
L 83,7  
P 5  
H 74,3

L 59,8  
P 5  
H 110,3

L 41,6  
P 83,7  
H 110,3

**Mensole**  
Shelves | Etageres

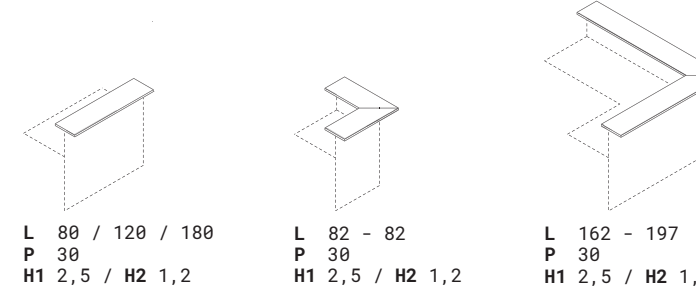

L 80 / 120 / 180  
P 30  
H1 2,5 / H2 1,2

L 82 - 82  
P 30  
H1 2,5 / H2 1,2

L 162 - 197  
P 30  
H1 2,5 / H2 1,2

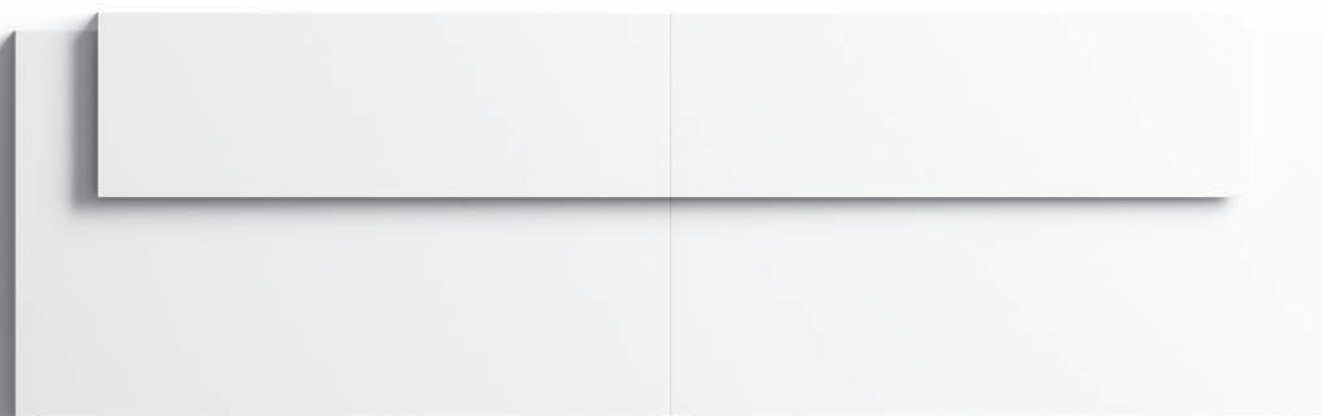

**Una collezione reception che si caratterizza per:**

**01/** Elevata componibilità. **02/** Mensole in legno e metallo. **03/** Moduli conversazione centrali e terminali ad altezza 73,6 cm. **04/** Modulo angolare. **05/** Allunghi laterali. **06/** Vaschette passacavi e kit di elettrificazione. **07/** Led opzionale sotto mensola. **08/** Combinazione bicolore struttura-mensola. **09/** 2 finiture di legni e 3 tinte unite. **10/** 3 finiture di legni e 3 tinte unite per mensole legno. **11/** 9 finiture per mensole metalliche.

**A collection of reception counters characterised by:**

**01/** High modularity. **02/** Wood and metal shelves. **03/** Speak-through central modules and end-side elements, height 73.6 cm. **04/** Corner module. **05/** Side extensions. **06/** Cable and wiring trays and fittings. **07/** Optional LED light under the shelf. **08/** Two-colour combination for shelves and structural elements. **09/** 2 wood finishes, 3 plain colours. **10/** 3 wood finishes and 3 plain colours for the wooden shelves. **11/** 9 finishes available for metal shelves.

**Une collection de comptoirs d'accueil caractérisée par :**

**01/** Haute modularité. **02/** Étagères en bois et métal. **03/** Module conversation central et terminal à hauteur 73,6 cm. **04/** Module angulaire. **05/** Rallonges latérales. **06/** Panier passe-câbles et kit électricité. **07/** LED en option dessous l'étagère. **08/** Combinaison à deux couleurs structure-étagères. **09/** 2 finitions en bois et 3 couleurs pleins. **10/** 3 finitions en bois et 3 couleurs pleins pour les étagères en bois. **11/** 9 finitions pour les étagères en métal.











**Point è una reception ispirata a criteri di rigore formale che si articola in moduli variamente aggregabili tra loro. La semplicità compositiva e lo stile minimale generano infinite composizioni, con forme e dimensioni differenti, adattabili in ogni contesto.**

The Point reception desk is inspired to formal rigour criteria declined in versatile modules that can be combined together. The simplicity in the composition and its minimal style generate infinite combinations, with different shapes and sizes, that can be adapted to any context.

Point est un comptoir inspiré aux critères de rigueur formelle articulés dans de modules qui peuvent être différemment combinés. La simplicité de la composition et son style minimaliste permettent de créer des compositions infinies, avec différentes formes et tailles, adaptables dans tous les contextes.

→ Fianco strutturale che chiude lateralmente ogni modulo.  
Side structural element that literally closes each module.  
Côté structurel qui ferme chaque module latéralement.

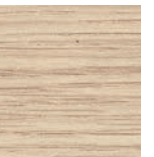

cod. 03











**I moduli più semplici e di dimensioni ridotte garantiscono le stesse dotazioni e funzionalità delle composizioni più articolate. I piani di lavoro, differenti per ospiti ed operatori, si distinguono chiaramente per l'altezza da terra.**

The simplest and the smallest modules provide the same features and functionality as the most complex compositions. Different worktops for guests and operators, clearly distinguishable by their height.

Les modules les plus simples et les plus petits offrent les mêmes caractéristiques et fonctionnalités de compositions les plus articulées. Les plans de travail, différents pour les visiteurs et les opérateurs, se distinguent clairement par leur hauteur par rapport au sol.

cod. 63

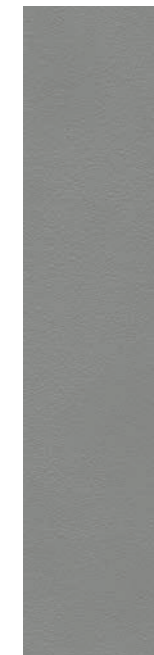

cod. 38



cod. SG 01



→ Piano di ricevimento per ospiti disabili.

Reception worktop for disabled guests.

Plan d'accueil pour personnes à mobilité réduite.







←  
Composizione  
lineare per  
relatori in sale  
conferenze o  
formazione.

Linear composition  
for speakers in  
conference or  
training rooms.

Composition  
linéaire pour  
les intervenants  
dans les salles  
de conférence  
ou de formation.

**La linearità dei frontali viene articolata dalle mensole metalliche, proposte in nove colori e dotate di led opzionali.**

**Il bancone di ricevimento, nella sua semplicità, permette di creare effetti sempre diversi sia in termini cromatici che compositivi.**

The linearity of fronts panels is highlighted by the metal shelves, available in nine colours and fitted with optional LEDs.

The reception counter, in its simplicity, allows to create different effects, in terms of colour and composition.

La linéarité des panneaux frontaux est définie par les étagères en métal, disponibles en neuf couleurs et équipées de LED en option. Le système, dans sa simplicité, permet de créer différents effets en termes de couleur et de composition.

cod.CL 01

cod.68



→  
Mensole lineari in  
acciaio verniciato  
in nove colori.  
Linear shelves in  
painted steel,  
available in nine  
colours.  
Étagères linéaires  
en acier peint en  
neuf couleurs.





**L'effetto cromatico e materico delle mensole metalliche valorizza il bancone di ricevimento evolvendo la linearità originaria del progetto.**

The chromatic and material effect of metal shelves adds value to the reception counter through the evolution of the original linearity of this project.

L'effet chromatique et des matériaux des étagères en métal valorise le comptoir d'accueil en soulignant l'évolution de la linéarité originale du projet.



cod.NR 03

→ Il ridotto spessore della lamiera enfatizza il pannello strutturale in legno.  
The reduced thickness of the metal sheet highlights the structural wooden panel.  
L'épaisseur réduite de la tôle souligne le panneau structurel en bois.

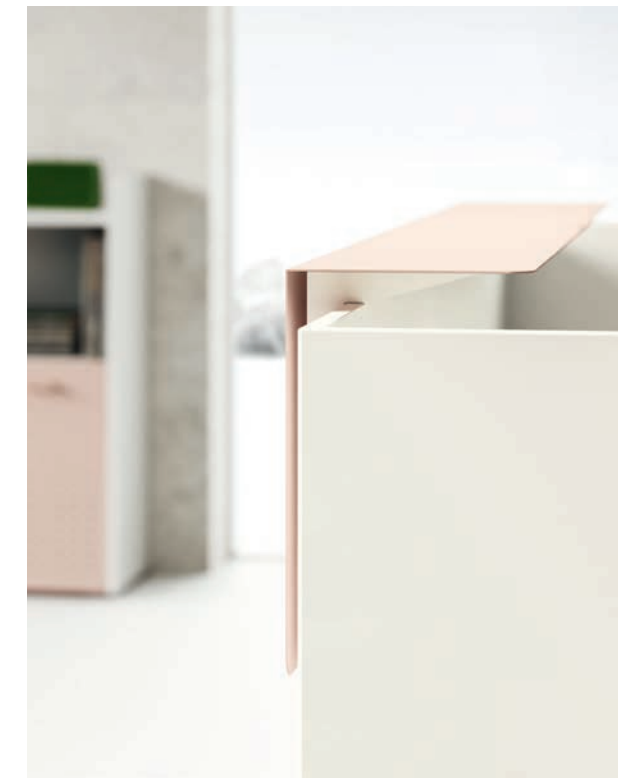

cod.CP 01

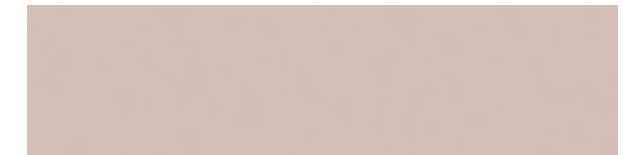

cod.VR 01

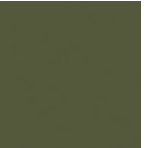





**Reception**  
Reception | Réception

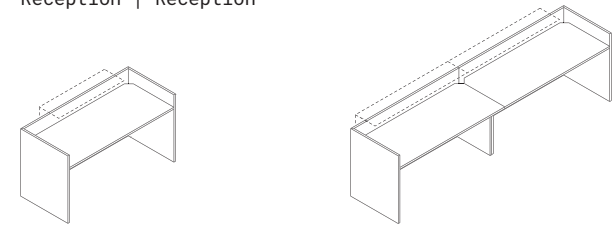

L 125 / 145 / 165 / 185  
P 72,5  
H 105

L 245 / 285 / 325 / 365  
P 72,5  
H 105

**Moduli**  
Modules | Modules

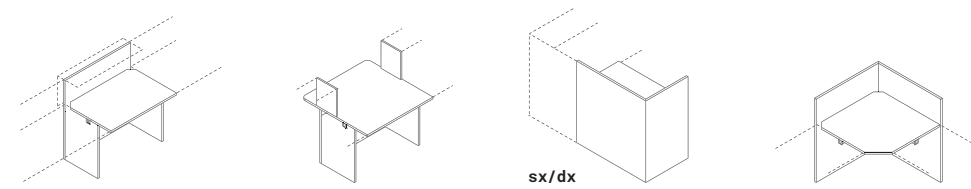

L 100  
P 72,5  
H 105

L 100  
P 100  
H 105

sx/dx

L 102,5  
P 62,5  
H 105

L 92,5  
P 92,5  
H 105

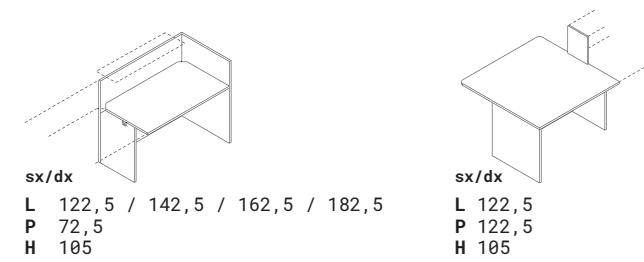

sx/dx  
L 122,5 / 142,5 / 162,5 / 182,5  
P 72,5  
H 105

sx/dx  
L 122,5  
P 122,5  
H 105

**Mensole**  
Shelves | Etageres

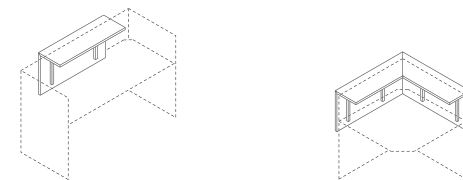

L 100 / 120 / 140 / 160  
P 30  
H 50

L 97,5 - 97,5  
P 30  
H 50

**Cattedre**  
Conference desks | Bureaux conference

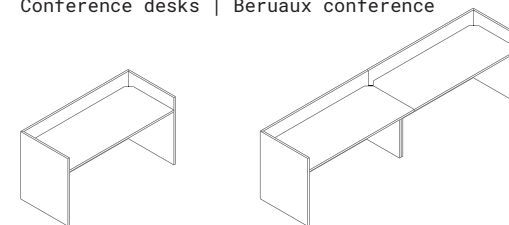

L 165  
P 72,5  
H 90

L 325  
P 72,5  
H 90